

The World's Fastest 3D Printer Just Got Faster

Presenting the ZPrinter® 310 Plus.
Faster. Sharper. Stronger.



Z CORPORATION®

Presenting the ZPrinter® 310 Plus



- Enhanced version of the ZPrinter 310, the fastest, easiest, most affordable way to produce physical models of 3D CAD designs
- Incorporates technologies previously available only in our premium high-definition color printers
- Produce concept models faster, see crisper details, and produce thin-walled parts with ease
- Same affordable low price

All Prices in US \$

ZPrinter® 310 Plus is an Output Device for 3D CAD Data



3D CAD File

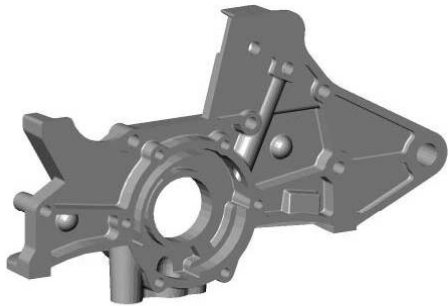

3D Printer



3D Model





Z CORPORATION®

How it Works

- Software “slices” CAD file into thousands of thin layers
- Physical model is built one layer at a time
- Ink-jet print heads deposit binder into powder to create layers

1

Spread Layer of Powder

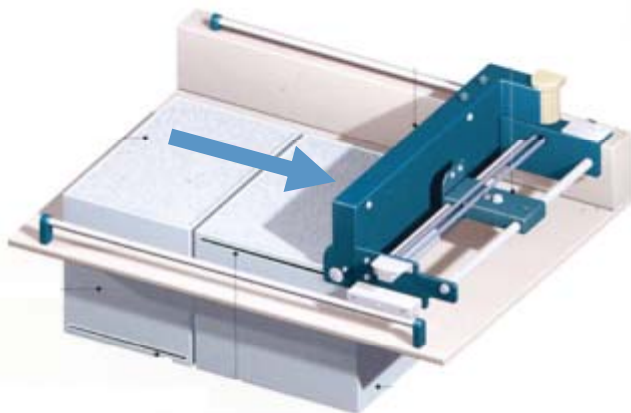

2

Print Cross-Section

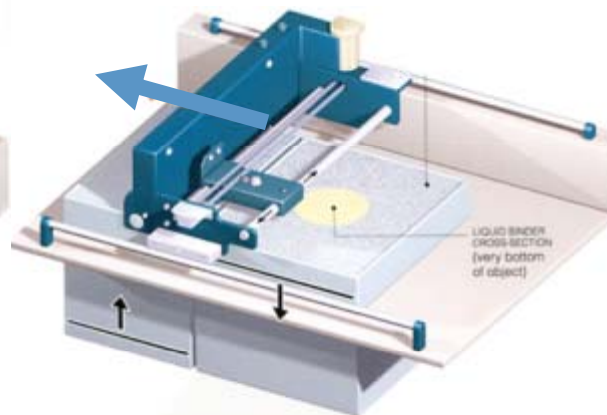

3

Spread Layer of Powder

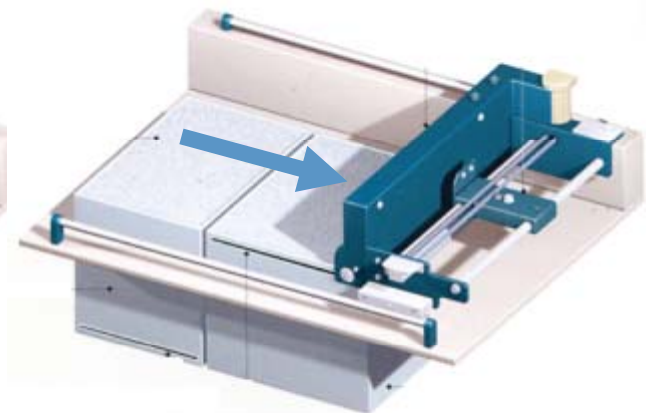

Tangible Models Enable You to Communicate More Clearly



Z CORPORATION®



Streamline Design, Sales & Marketing



- Streamline design
 - Create more prototypes, sooner
 - Make ideas easier to visualize
 - Make decisions faster by reviewing tangible options
 - Identify form, fit, function errors early
 - Improve communication with suppliers, vendors, customers
- Jumpstart Sales & Marketing
 - Create realistic prototypes for focus groups
 - Develop and evaluate packaging options
 - Begin selling with realistic models long before manufacturing delivers product

The Breakthrough Advantages of the Original ZPrinter® 310



Z CORPORATION®

- 5-10x faster than other RP technologies
- Affordable price with the industry's lowest operating cost
- Best-in-class parts
- Easy-to-use, versatile materials, easy, modular servicing
- Build area
 - 203 x 254 x 203 mm (8 x 10 x 8 in.)
- Layer thickness
 - .089 - .203 mm (.0035 - .008 in.)



The Advantages of the ZPrinter® 310 ...Plus up to 25% Faster



- Up to 25% faster print time
- 5-10x faster than other rapid prototyping technologies
- Shorter total process time

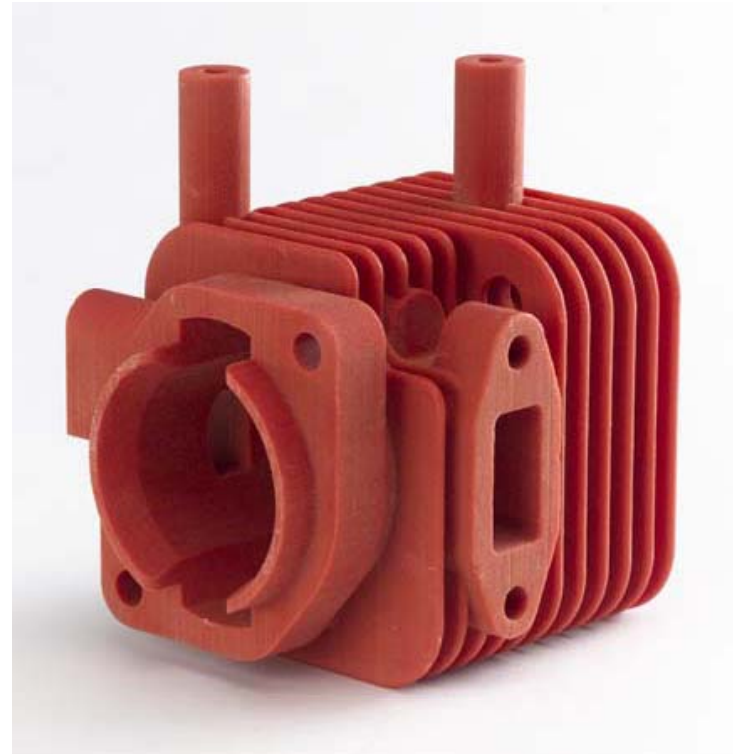

The Advantages of the ZPrinter® 310 ...Plus 50% Higher Resolution



Z CORPORATION®

- Resolution increased from 300 x 300 dpi to 300 x 450 dpi
- Best-in-class
 - Most detailed parts available
 - Smoother surface finish, particularly bottom-facing
- Improved firmware
 - Enhanced algorithms for better surfaces
 - Finer control of print head motion



The Advantages of the ZPrinter® 310 ...Plus Support for Fine Detail



- Print more complex geometries and small features
- New heated build chamber for improved material performance
 - Better feature definition
 - Shorter process time
 - More vibrant single colors



ZPrinter® 310 Plus Price & Availability



- Same affordable low price
- Shipped October 2005

All Prices in US \$

For More Information



- Visit www.zcorp.com
- Contact a Z Corporation dealer. To find a dealer near you, call:
 - Z Corporation USA (Telephone: +1 781 852 5005)
 - Z Corporation Europe (Telephone: +44 (0)8702 416502)
 - Z Corporation Asia Pacific (Telephone: +1 781 852 5005)

The World's Fastest 3D Printer Just Got Faster

Presenting the ZPrinter® 310 Plus.
Faster. Sharper. Stronger.



Z CORPORATION®